

TICO EXCLUSIVE DEALER FOR EUROPE

# TICO

*TRAILERS ON THE MOVE...*



**Antwerp Terminal Tractors & Reachstackers**



**ATTR** NV  
Turnhoutsebaan 17 - 19  
3980 TESSENDERLO  
BELGIUM

Tel.: +32 14 84 00 71  
Fax.: +32 14 84 01 41  
Mail: [info@attr.be](mailto:info@attr.be)  
Site: [www.attr.be](http://www.attr.be)

# TICO TERMINAL TRACTOR



## Two types of engines:

- LOLO: 160 HP Cummins QSBIII 6,7 L electronic diesel engine mated to an Allison RDS 3500 electronic automatic world transmission.
- RORO: 215 HP Cummins QSBIII 6,7 L electronic diesel engine mated to an Allison RDS 3500 electronic automatic world transmission.



## Visibility:

- From inside the cab the trailer is 100% visible. The air operated double rear door facilitates the connection and disconnection of trailers.

## Entrance:

- Safe and easy entrance and exit to connect and disconnect air hoses.

## Lighting:

- The lighting has been put together perfectly. The use of orange lights around the cabin makes this tractor a striking and exclusive product.



## Cab:

- Cab:
- Low noise cabin with panoramic visibility.
- Easy to operate ergonomic dashboard.
- Drive front and back by means of push buttons and automatic gear switch.



## Fifth wheel:

- Hydraulic operated fifth wheel, adjustable in height.



### Tilting of cab:

- Cab can be tilted hydraulically, operated electrically by means of a separate oil pump.

### Steering:

- Hydraulic steering system. Consists of mechanical steering, assisted hydraulically. Is very safe and has hydraulic emergency steering property.



### Suspension:

Excellent suspension for the driver.

- front wheels: leaf springs
- air-suspended cabin

## DIMENSIONS

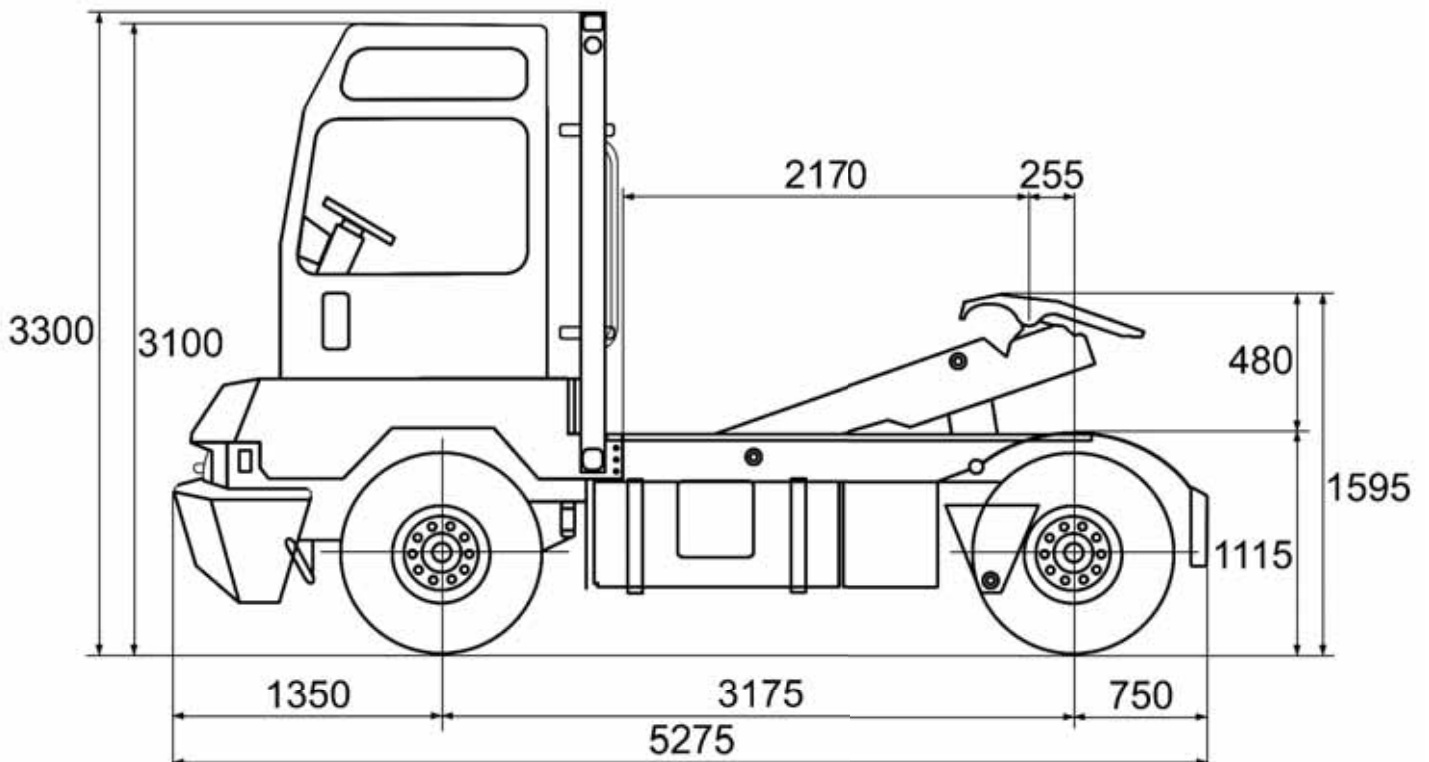

# SPECIFICATIONS

## ENGINE:

- Make: Cummins
- Type: QSB III 6.7
- Max. output Lolo: 119 Kw (160 hp)
- Max. output Roro: 160 Kw (215 hp)
- Max. torque Lolo: 732 Nm @ 1400 rpm
- Max. torque Roro: 888 Nm @ 1500 rpm
- Displacement: 6.7 L

## TRANSMISSION:

- Allison automatic transmission with torque converter
- Type: Allison RDS 3500
- Gears: 4 forward / 1 reverse
- Max. speed: 40 km/h - adjustable

## TYRES:

- Front: 11 x R22.5 air tyres
- Rear: 11 x R22.5 air tyres

## STEERING:

- Mechanical steering wheel
- Assisted hydraulically

## FRONT AXLE / Brakes:

- Arvin Meritor FG943 (Lolo & Roro)

## REAR AXLE / Brakes:

- Arvin Meritor 30-380 (Lolo)
- Sisu SRDP (Roro)

## FRONT SUSPENSION:

- Leaf springs

## REAR SUSPENSION:

- Built against chassis

## ELECTRICAL CIRCUIT:

- 24 Volt
- 24 Volt starter

## CAB:

- very spacious and high one-man cab
- mounted on the left
- large panoramic visibility
- ergonomic dashboard design
- air-suspended cab
- cab can be tilted hydraulically
- air operated double rear door facilitates entrance and exit
- steps and walkways with non-slip surfaces
- low noise cab
- tinted glass/ windscreen wipers and sprinklers
- air-suspended driver seat
- 2 exterior mirrors left and right
- 2 ventilators left and right
- complete road lighting
- work lights front and back and on the side
- beacon light
- large 2 cylinder compressor on engine
- extra large air tank
- electronic control unit checks:
  - oil pressure engine and transmission
  - temperature engine and transmission
  - engine revolutions
  - fuel level, etc.
- forward and reverse gear switch security

## FIFTH WHEEL:

- SafHolland 2" fifth wheel
- Capacity: 20.000 kg
- Type FW3510 TR-EG
- Pneumatic and manual unlocking

## FUEL TANK:

- 1 Fuel tank, capacity 220 liter



## Antwerp Terminal Tractors & Reachstackers



**ATTR** NV  
Turnhoutsebaan 17 - 19  
3980 TESSENDERLO  
BELGIUM

Tel.: +32 14 84 00 71  
Fax.: +32 14 84 01 41  
Mail: [info@attr.be](mailto:info@attr.be)  
Site: [www.attr.be](http://www.attr.be)